

ESSENTIAL

TBS30-60Q Series

TOW TRUCK

3.0-6.0 tonnes

**UNMATCHED TOUGHNESS
MAXIMUM PERFORMANCE**

The TBS30-60Q Series of tow trucks are built for applications that demand endurance over long distances. They can cope with tough working requirements safely and effectively, and with towing speeds up to 7 km/h and unladen speeds up to 14 km/h you can work swiftly and productively.

SPECIFICATIONS

TBS30Q
TBS60Q



**WHEN
RELIABILITY IS
EVERYTHING...**

ESSENTIAL

TBS30-60Q Series

TOW TRUCK

3.0-6.0 tonnes

BRAKES

- **Mechanical hand brake**
Simple, effective, and low maintenance.
- **Electromagnetic braking system**
Smooth, steady deceleration (Standard on 3-tonne models, option on 6-tonne models)

DRIVE

- **Powerful AC drive motor**
Excellent traction, smooth, quiet, controlled operation, extended shift length and lower maintenance requirements.
- **High travel speeds**
Up to 14 km/h when unladen, 7 km/h towing at capacity.

ELECTRICAL AND CONTROL SYSTEMS

- **Sideways battery exchange**
Quick and easy battery change in multi-shift operations.
- **High-quality connectors**
These reduce the need for maintenance and repair.
- **Battery discharge indicator**
Fitted as standard for battery protection and shows operating hours, battery level, and error codes.
- **IP65 AC controller**
Good protection against water and dust ingress.
- **Li-ion battery**
Fast opportune charging removes the need for extra batteries and allows 24/7 operation. (Option)
- **External charger**
It's possible to charge the battery onboard.

FRAME AND BODY

- **Standard combination lights**
These offer good forward illumination and help to alert nearby pedestrians of the truck's approach.
- **Heavy duty hood**
Protection from impacts and from water ingress during light showers.
- **Manual tow coupling**
Quick release tow pins for fast and easy locking and unlocking of the tow hook.
- **LED lights**
Front, rear, and turning lights help illuminate dark environments and make the truck more visible to nearby pedestrians.

OPERATOR COMPARTMENT AND CONTROLS

- **RapidAccess features**
Get quick and easy entry to all areas for checks and servicing.
- **Multi-function display**
Show battery status, error codes, hour meter and more.
- **Electric power steering**
Comfortable, precise control, smooth cornering, and less operator fatigue. (Option)
- **Adjustable steering column**
Angle can be altered to make operation more comfortable.
- **Partially enclosed cabin**
Offers protection against light rain. (Option)
- **Walk-beside drive button**
This makes coupling and uncoupling easy as the operator doesn't have to keep entering and exiting the truck.
- **Safety seat switch**
This locks all movement of the truck and its mast if the operator is not present. (Option)

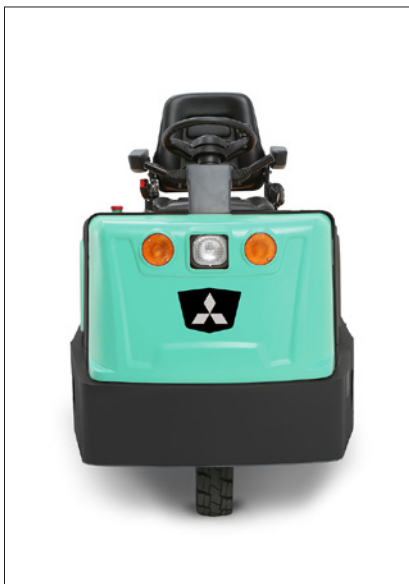

For more information on
TBS30-60Q Series please
visit our website





PREMIA EX

LI-ION BATTERY SYSTEMS

MAKE YOUR FORKLIFT GO EVEN FURTHER

Tried, tested and proven in the field, lead-acid batteries have been the long-standing choice for companies employing electric lift trucks. However, with long charging times, demanding maintenance requirements, the need for extra batteries, and high risk of operator misuse, day-to-day use can be a challenge.

Fortunately, there's a new battery system on the block: Li-ion from Mitsubishi Forklift Trucks.

Designed to meet your business' demands — including multi-shift (24/7) operations — without the need for spare batteries, our high-performance Li-ion battery system is up to 30% more efficient than lead-acid counterparts. Plus, it's virtually error-proof, thanks to its ultra-low-maintenance design which prevents cell damage.

- **Gas-emission free**
No need for air ventilation.

- **Exceptional high battery and charger efficiency**
State-of-the-art technology delivers up to 30% more power efficiency than lead-acid batteries.
- **Maintenance-free design**
No need for daily checks and water re-fills. This reduces the risk of operators damaging cells and reducing their lifetime. Needs a full charge each week to activate cell balancing.
- **No need for spare batteries or charging room**
You can save both space and costs in multi-shift applications, maximising profitability.
- **Quick charge capabilities**
Just 15 minutes is all your battery needs to keep your truck going for a few more hours. It only takes 1 to 2 hours to fully charge a completely discharged battery.

- **Higher sustained voltage**
This gives more consistent lifting and driving performance — particularly noticeable towards the end of a shift.
- **Multiple safety features**
This includes circuit protection, deep-discharge and overcharge protection, and individual cell temperature and voltage monitoring.
- **On-the-go performance and monitoring**
The system's integrated monitoring system has an easy-to-read display unit.
- **Wide choice of battery and charger capacities**
The most suitable power supply can be matched to the exact requirements of a specific application.



Clean Li-ion batteries are ideal for sensitive environments such as those in the food or packaging industries.

Fully integrated Li-ion battery

Features a sophisticated CANbus communication and an automatic ON/OFF synchronization between battery and truck. Battery level, notifications and alarms are integrated into the truck display, to secure clear and easy overview for the truck operator.

For more information on Li-ion please visit our website



VDI - PERFORMANCE & DIMENSIONS

CHARACTERISTICS				Mitsubishi Forklift Trucks	Mitsubishi Forklift Trucks
1.1	Manufacturer			TBS30Q	TBS60Q
1.2	Manufacturer's model designation			Battery	Battery
1.3	Power source			Seated	Seated
1.4	Operator type			3000	6000
1.5	Load capacity	Q	kg	750 / 75	1500 / 150
1.7	Rated drawbar pull	F	N	1055	1280
1.9	Wheelbase	y	mm		
WEIGHT					
2.1b	Truck weight without load, with maximum battery weight		kg	780	1280
2.2	Axle loadings with nominal load & maximum battery weight, drive / load side		kg	310	830
2.3	Axle loadings without load & with maximum battery weight, drive / load side		kg	470	450
WHEELS, DRIVE TRAIN					
3.1	Tyres: PT = Power Thane, Vul = Vulkollan, P = Polyurethane, N = Nylon, R = Rubber drive / load side			Solid - rubber	Solid - rubber
3.2	Tyre dimensions, drive side		mm	15"4 ½-8	15"4 ½-8
3.3	Tyre dimensions, load side		mm	15"4 ½-8	4.00 - 8
3.5	Number of wheels, load / drive side (x = driven)			1 / 2x	1 / 2x
3.7	Track width (center of tyres), load side	b11	mm	860	946
DIMENSIONS					
4.8	Seat- or stand height	h7	mm	910	910
4.12	Tow coupling height	h10	mm	280 / 350	280 / 350
4.19	Overall length	l1	mm	1720	1940
4.21	Overall width	b1/b2	mm	968	1100
4.32	Ground clearance at center of wheelbase, (forks lowered)	m2	mm	90	100
4.35	Turning radius	Wa	mm	1490	1650
PERFORMANCE					
5.1	Travel speed, with / without load		km/h	6.5 / 10	7 / 14
5.7	Gradeability, with / without load		%	8 / 10	6 / 15
5.10	Service brakes (mechanical / hydraulic / electric / pneumatic)			Mechanical / hydraulic	Mechanical / hydraulic
ELECTRIC MOTORS					
6.1	Drive motor capacity (60 min. short duty)		kW	3	5
6.4	Battery voltage/capacity at 5-hour discharge		V/Ah	36 / 250	48 / 350
6.5	Battery weight		kg	115	220
MISCELLANEOUS					
8.1	Type of drive control			Stepless	Stepless
10.7	Level of noise at the ear level of the driver according to EN 12 053:2001 and EN ISO 4871 in work LpAZ		dB(A)	68	68

ESSENTIAL

TBS30-60Q Series

TOW TRUCK

3.0-6.0 tonnes

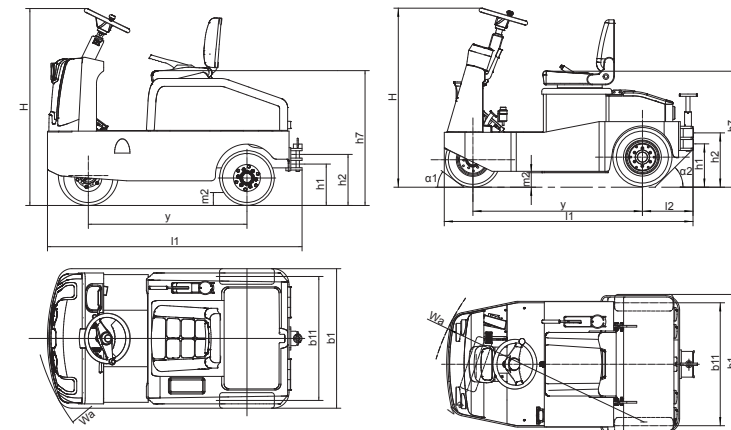

WHEN RELIABILITY IS EVERYTHING...



ESSENTIAL
SIMPLE. RELIABLE.
ECONOMICAL.

High quality, low cost.

The ESSENTIAL range of warehouse products is ideal for low- to medium-intensity operations in a huge number of different applications. The tough, low-maintenance designs offer excellent value for money.

Like any product bearing the Mitsubishi Forklift Trucks name, our materials handling equipment benefits from the tremendous heritage, huge resources and cutting-edge technology of one of the world's largest corporations – Mitsubishi Heavy Industries Group.

Engineering spacecraft, jet planes, power plants and more, MHI specialises in those technologies where performance, dependability and superiority decide your success or failure...

So when we promise you quality, reliability and value for money, you know it's a guarantee we have the power to deliver.

That's why every model in our award-winning and comprehensive range of lift trucks and warehouse equipment is built to a high specification – to ensure it keeps working for you. Day after day. Year after year. Whatever the job. Whatever the conditions.

YOU'LL NEVER WORK ALONE

As your local authorised dealer, we are here to keep your trucks working – through our extensive experience, our technical excellence and our commitment to customer care.

We are your local experts, backed by efficient channels to the entire organisation of Mitsubishi Forklift Trucks.

No matter where you are, we are close by – with the capability to meet your needs.

Discover how Mitsubishi Forklift Trucks give you more from your local authorised distributor or when you visit our website www.mitforklift.com

Performance specifications may vary depending on standard manufacturing tolerances, vehicle condition, types of tyres, floor or surface conditions, applications or operating environment. Trucks may be shown with non-standard options. Specific performance requirements and locally available configurations should be discussed with your distributor of Mitsubishi forklift trucks. We follow a policy of continual product improvement. For this reason, some materials, options and specifications could change without notice.

info@mitforklift.com

WESM2468 © 2024 MLE



Mitsubishi Logisnext Europe B.V.
Hefbrugweg 77, 1332 AM Almere
The Netherlands
Tel: +31 (0)36 5494 411



mft2.eu/fb



mft2.eu/apps



mft2.eu/youtube



mft2.eu/facebook

